



**MANDRINERIA
PER MACCHINE TRADIZIONALI E CNC
PER LA LAVORAZIONE DEL LEGNO**

**TOOL HOLDERS
FOR TRADITIONAL AND CNC
WOODWORKING MACHINES**

16



16



16

	pagina page	
PORTAPINZE - PORTAFRESE COLLET CHUCKS - MILLING CHUCKS		
Mandrini portapinze con attacco HSK 50/63 DIN 69893 Collect chucks HSK 50/63 - DIN 69893	4	
Mandrini portapinze con attacco cono morse Morse taper collet chucks	4	
Mandrini portapinze con attacco ISO 30/40 Collet chucks ISO 30/40	5	
Mandrini portapinze con attacco ISO 30 Collet chucks ISO 30	5	
Mandrini portapinze con attacco ISO 30/40 flangia di cambio utensile ø 58 Collet chucks ISO 30/40 flange ø 58	6	
Mandrini portapinze con attacco ISO 30 a flangia dentata Collet chucks ISO 30 with toothed flange	6	
Mandrini portafrese con attacco HSK 50/63 DIN 69893 Milling chuck HSK 50/63 DIN 69893	6-7	
Mandrini portafrese con attacco ISO 30/40 Milling chuck ISO 30/40	8-9	
Mandrini portafrese con attacco ISO 30 a flangia dentata Milling chuck ISO 30 with toothed flange	9	

	pagina page	
RICAMBI SPARE PARTS		
Tiranti di aggancio per mandrini Pull studs for chucks	10	
Pinze e ghiera tipo ER DIN 6499 Collets and nuts ER DIN 6499	11	
Pinze e ghiera tipo EOP DIN 6388 Collets and nuts EOP DIN 6388	12	
Pinze e ghiera tipo ETS Collets and nuts ETS	12-13	
Ghiere di contrasto Spacers	13	
Viti Screws	13	
Flange di bloccaggio per portafrese Locking flanges for milling chucks	14	
Chiavi per ghiera Wrenches for nuts	14	
Smontaconi Tool setting stands	14	

MANDRINI PORTAPINZE COLLET CHUCKS

MANDRINI PORTAPINZE ATTACCO HSK DIN 69893 COLLET CHUCKS HSK DIN 69893

ART.	D2	H1 mm	H mm	D mm	D1 mm	Pinza Collet	Rot. Rev.
22250E32D	50/E	25	73	3-20	50	ER/32	dx / r
22250E32SX	50/E	25	73	3-20	50	ER/32	sx / l
22250E40D	50/E	25	75	4-30	63	ER/40	dx / r
22250E40SX	50/E	25	75	4-30	63	ER/40	sx / l
22250EEOP25	50/E	25	90	2-25	60	EOP/25	dx / r
22263E32D	63/E	32	78	3-20	50	ER/32	dx / r
22263E32SX	63/E	32	78	3-20	50	ER/32	sx / l
22263E40D	63/E	32	75	4-30	63	ER/40	dx / r
22263E40SX	63/E	32	75	4-30	63	ER/40	sx / l
22263EEOP25D	63/E	32	90	2-25	60	EOP/25	dx / r

Per macchina / For machine: CMS, Uniteam

ART.	D2	H1 mm	H mm	D mm	D1 mm	Pinza Collet	Rot. Rev.
22250F32D	50/F	20	73	3-20	50	ER/32	dx / r
22250F32SX	50/F	20	73	3-20	50	ER/32	sx / l
22250F40D	50/F	20	75	4-30	63	ER/40	dx / r
22250F40SX	50/F	20	75	4-30	63	ER/40	sx / l
22250FEOP25D	50/F	20	90	2-25	60	EOP/25	dx / r

Per macchina / For machine: Biesse, SCM, Morbidelli, Eima, Dubus, Weeke

ART.	D2	H1 mm	H mm	D mm	D1 mm	Pinza Collet	Rot. Rev.
22263F32D	63/F	25	73	3-20	50	ER/32	dx / r
22263F32SX	63/F	25	73	3-20	50	ER/32	sx / l
22263F40D	63/F	25	80	4-30	63	ER/40	dx / r
22263F40SX	63/F	25	80	4-30	63	ER/40	sx / l
22263FEOP25	63/F	25	90	2-25	60	EOP/25	dx / r

Per macchina / For machine: Biesse, Eima, Homag, SCM, Ima (da 9/94), Weeke, Dubus, Busellato

BILANCIATI FINO A G.2,5 - 24.000 RPM a richiesta
BALANCED TO 24,000 RPM at G.2,5 on request

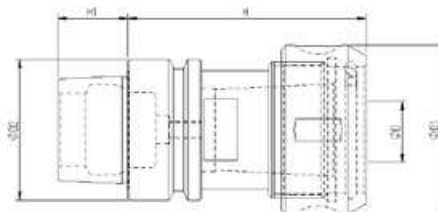

MANDRINI PORTAPINZE ATTACCO CONO MORSE MORSE TAPER COLLET CHUCKS

ART.	CM MT	H mm	D mm	D1 mm	D2 mm	Pinza Collet	Rot. Rev.
2220232D	2	62	3-20	50	M30x1,5	ER/32	dx / r
2220232SX	2	62	3-20	50	M30x1,5	ER/32	sx / l
2220232DF20	2	85	3-20	50	W20x14	ER/32	dx / r
2220232SXF20	2	85	3-20	50	W20x14	ER/32	sx / l
2220332D	3	70	3-20	50	M30x1,5	ER/32	dx / r
2220332SX	3	70	3-20	50	M30x1,5	ER/32	sx / l
2220340D	3	80	4-30	63	M30x1,5	ER/40	dx / r
2220340SX	3	80	4-30	63	M30x1,5	ER/40	sx / l

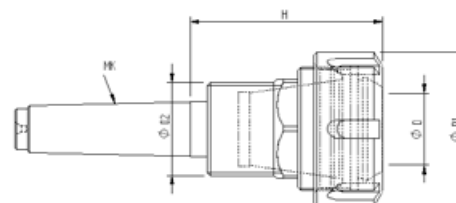

MANDRINI PORTAPINZE COLLET CHUCKS

MANDRINI PORTAPINZE ATTACCO DIN 69871 COLLET CHUCKS DIN 69871

ART.	ISO	D2 mm	H1 mm	D3 mm	H mm	D mm	D1 mm	Pinza Collet	Rot. Rev.
2223032BSD	30	31,75	47,8	50	50	3-20	50	ER/32	dx / r
2223032BSSX	30	31,75	47,8	50	50	3-20	50	ER/32	sx / l
2223040BSD	30	31,75	47,8	50	57	4-30	63	ER/40	dx / r
2223040BSSX	30	31,75	47,8	50	57	4-30	63	ER/40	sx / l

Per macchina / For machine: Biesse, Cosmec, Masterwood

ART.	ISO	D2 mm	H1 mm	D3 mm	H mm	D mm	D1 mm	Pinza Collet	Rot. Rev.
2223032D	30	31,75	47,8	50	68	3-20	50	ER/32	dx / r
2223032SX	30	31,75	47,8	50	68	3-20	50	ER/32	sx / l
2223040D	30	31,75	47,8	50	68	4-30	63	ER/40	dx / r
2223040SX	30	31,75	47,8	50	68	4-30	63	ER/40	sx / l
22230EOP25D	30	31,75	47,8	50	70	2-25	60	EOP/25	dx / r

Per macchina / For machine: Biesse, SCM, Morbidelli, Eima, Dubus, Weeke, Alberti

ART.	ISO	D2 mm	H1 mm	D3 mm	H mm	D mm	D1 mm	Pinza Collet	Rot. Rev.
2224032D	40	44,45	68,4	63,55	68	3-20	50	ER/32	dx / r
2224032SX	40	44,45	68,4	63,55	68	3-20	50	ER/32	sx / l
2224040D	40	44,45	68,4	63,55	68	4-30	63	ER/40	dx / r
2224040SX	40	44,45	68,4	63,55	68	4-30	63	ER/40	sx / l
22240EOP25D	40	44,45	68,4	63,55	74	2-25	60	EOP/25	dx / r

Per macchina / For machine: Biesse, SCM, Ima, Maka, Weeke, Bulleri, Reichenbacher, Stegherr
BILANCIATI FINO A G.2,5 - 24.000 RPM a richiesta
BALANCED TO 24,000 RPM at G.2,5 on request

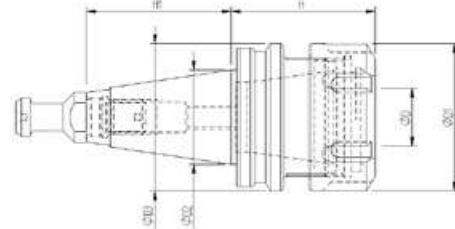

MANDRINI PORTAPINZE ATTACCO DIN 69871 COLLET CHUCKS DIN 69871

ART.	ISO	D2 mm	H1 mm	D3 mm	H mm	D mm	D1 mm	Pinza Collet	Rot. Rev.
2223032F46D	30	31,75	47,8	46	60	3-20	50	ER/32	dx / r
2223032F46SX	30	31,75	47,8	46	60	3-20	50	ER/32	sx / l
2223040F46D	30	31,75	47,8	46	65	4-30	63	ER/40	dx / r
2223040F46SX	30	31,75	47,8	46	65	4-30	63	ER/40	sx / l
22230EOP25F46D	30	31,75	47,8	46	70	2-25	60	EOP/25	dx / r

Per macchina / For machine: CMS
BILANCIATI FINO A G.2,5 - 24.000 RPM a richiesta
BALANCED TO 24,000 RPM at G.2,5 on request

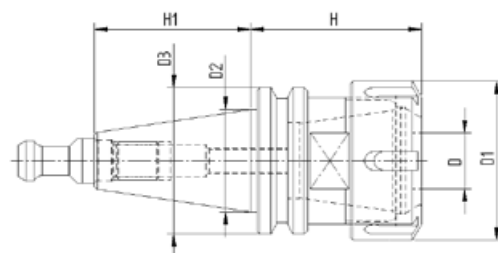

MANDRINI PORTAPINZE - PORTAFRESE COLLET AND MILLING CHUCKS

MANDRINI PORTAPINZE ATTACCO DIN 69871 COLLET CHUCKS DIN 69871

ART.	ISO	D2 mm	H1 mm	D3 mm	H mm	D mm	D1 mm	Pinza Collet	Rot. Rev.
2223032F58D	30	31,75	47,8	58	63	3-20	50	ER/32	dx / r
2223032F58SX	30	31,75	47,8	58	63	3-20	50	ER/32	sx / l
2223040F58D	30	31,75	47,8	58	65	4-30	63	ER/40	dx / r
2223040F58SX	30	31,75	47,8	58	65	4-30	63	ER/40	sx / l
22230EOP25F58D	30	31,75	47,8	58	70	2-25	60	EOP/25	dx / r
2224032F58D	40	44,45	68,4	58	63	3-20	50	ER/32	dx / r
2224032F58SX	40	44,45	68,4	58	63	3-20	50	ER/32	sx / l
2224040F58D	40	44,45	68,4	58	65	4-30	63	ER/40	dx / r
2224040F58SX	40	44,45	68,4	58	65	4-30	63	ER/40	sx / l
22240EOP25F58D	40	44,45	68,4	58	70	2-25	60	EOP/25	dx / r

Per macchina / For machine: Esseteam, Uniteam, Tekteam
BILANCIATI FINO A G.2,5 - 24.000 RPM a richiesta
BALANCED TO 24,000 RPM at G.2,5 on request

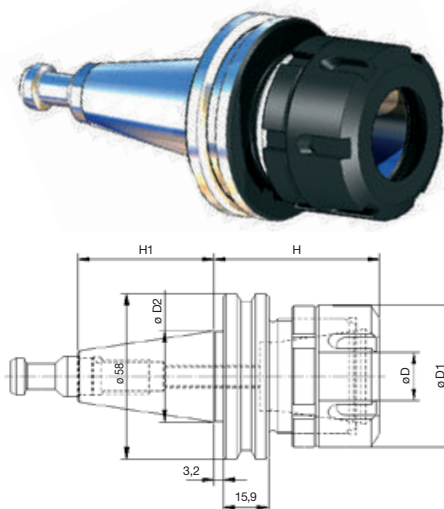

MANDRINI PORTAPINZE ATTACCO DIN 69871 FLANGIA DENTATA COLLET CHUCKS DIN 69871 WITH TOOTHED FLANGE

ART.	ISO	H mm	D mm	D1 mm	Pinza Collet	Rot. Rev.
2223032SCMD	30	55	3-20	50	ER/32	dx / r
2223032SCMSX	30	55	3-20	50	ER/32	sx / l
2223040SCMD	30	74	4-30	63	ER/40	dx / r
2223040SCMSX	30	74	4-30	63	ER/40	sx / l
22230EOP25SCMD	30	70	2-25	60	EOP/25	dx / r

Per macchina / For machine: SCM, Morbidelli
BILANCIATI FINO A G.2,5 - 24.000 RPM a richiesta
BALANCED TO 24,000 RPM at G.2,5 on request

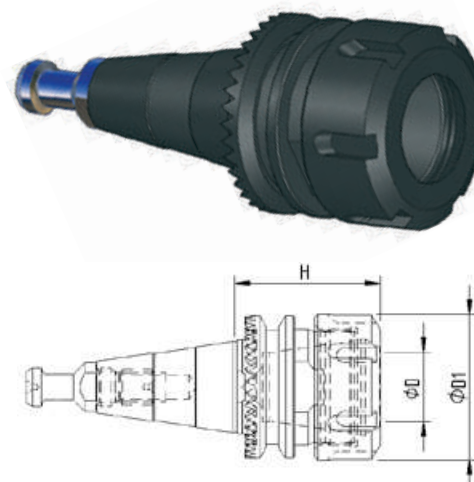

MANDRINI CON ALBERO PORTAFRESE ATTACCO HSK DIN 69893 CHUCKS WITH END MILL ARBOR HSK DIN 69893

ART.	D2	H2 mm	H1 mm	D mm	H mm	D1 mm
22363F20L70	63/F	25	33	20	70	35
22363F30L70	63/F	25	33	30	70	45
22363F30L80	63/F	25	33	30	80	45
22363F30L100	63/F	25	33	30	100	45
22363F30L150	63/F	25	33	30	150	45
22363F35L70	63/F	25	33	35	70	50
22363F35L80	63/F	25	33	35	80	50
22363F35L100	63/F	25	33	35	100	50
22363F35L150	63/F	25	33	35	150	50
22363F40L70	63/F	25	33	40	70	53
22363F40L80	63/F	25	33	40	80	53
22363F40L100	63/F	25	33	40	100	53
22363F40L150	63/F	25	33	40	150	53

Per macchina / For machine: SCM, Morbidelli
BILANCIATI FINO A G.2,5 - 24.000 RPM a richiesta
BALANCED TO 24,000 RPM at G.2,5 on request

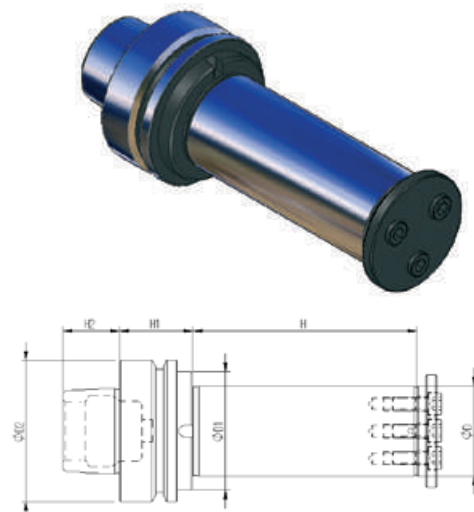

MANDRINI PORTAFRESE MILLING CHUCKS

MANDRINI CON ALBERO PORTAFRESE ATTACCO HSK DIN 69893 CHUCKS WITH END MILL ARBOR HSK DIN 69893

ART.	D2	H2 mm	H1 mm	D mm	H mm	D1 mm
22250E20L70	50/E	25	42	20	70	35
22250E30L70	50/E	25	42	30	70	45
22250E30L80	50/E	25	42	30	80	45
22250E30L100	50/E	25	42	30	100	45
22250E30L150	50/E	25	42	30	150	45
22250E35L70	50/E	25	42	35	70	49
22250E35L80	50/E	25	42	35	80	49
22250E35L100	50/E	25	42	35	100	49
22250E35L150	50/E	25	42	35	150	49
22263E20L70	63/E	32	42	20	70	35
22263E30L70	63/E	32	42	30	70	45
22263E30L80	63/E	32	42	30	80	45
22263E30L100	63/E	32	42	30	100	45
22263E30L150	63/E	32	42	30	150	45
22263E35L70	63/E	32	42	35	70	50
22263E35L80	63/E	32	42	35	80	50
22263E35L100	63/E	32	42	35	100	50
22263E35L150	63/E	32	42	35	150	50
22263E40L70	63/E	32	42	40	70	53
22263E40L80	63/E	32	42	40	80	53
22263E40L100	63/E	32	42	40	100	53
22263E40L150	63/E	32	42	40	150	53

Per macchina / For machine: SCM, Uniteam



ART.	D2	H2 mm	H1 mm	D mm	H mm	D1 mm
22250F20L70	50/F	20	42	20	70	35
22250F30L70	50/F	20	42	30	70	45
22250F30L80	50/F	20	42	30	80	45
22250F30L100	50/F	20	42	30	100	45
22250F30L150	50/F	20	42	30	150	45
22250F35L70	50/F	20	42	35	70	49
22250F35L80	50/F	20	42	35	80	49
22250F35L100	50/F	20	42	35	100	49
22250F35L150	50/F	20	42	35	150	49

Per macchina / For machine: Biesse, SCM, Morbidelli, Eima, Dubus, Weeke

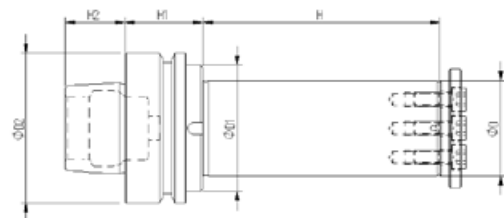

ART.	D2	H2 mm	H1 mm	D mm	H mm	D1 mm
22263F20L70	63/F	25	42	20	70	35
22263F30L70	63/F	25	42	30	70	45
22263F30L80	63/F	25	42	30	80	45
22263F30L100	63/F	25	42	30	100	45
22263F30L150	63/F	25	42	30	150	45
22263F35L70	63/F	25	42	35	70	50
22263F35L80	63/F	25	42	35	80	50
22263F35L100	63/F	25	42	35	100	50
22263F35L150	63/F	25	42	35	150	50
22263F40L70	63/F	25	42	40	70	53
22263F40L80	63/F	25	42	40	80	53
22263F40L100	63/F	25	42	40	100	53
22263F40L150	63/F	25	42	40	150	53

Per macchina / For machine: Biesse, Homag, Weeke, Ima (da 9/94), Eima, Busellato, Dubus

BILANCIATI FINO A G.2,5 - 24.000 RPM a richiesta
BALANCED TO 24,000 RPM at G.2,5 on request

MANDRINI PORTAFRESE MILLING CHUCKS

MANDRINI CON ALBERO PORTAFRESE ATTACCO DIN 69871 CHUCKS WITH END MILL ARBOR ATTACH DIN 69871

ART.	ISO	D2 mm	H2 mm	D3 mm	H1 mm	D mm	H mm	D1 mm
2223020L70	30	31,75	47,8	50	35	20	70	35
2223030L70	30	31,75	47,8	50	35	30	70	45
2223030L80	30	31,75	47,8	50	35	30	80	45
2223030L100	30	31,75	47,8	50	35	30	100	45
2223030L150	30	31,75	47,8	50	35	30	150	45
2223035L70	30	31,75	47,8	50	35	35	70	48
2223035L80	30	31,75	47,8	50	35	35	80	48
2223035L100	30	31,75	47,8	50	35	35	100	48
2223035L150	30	31,75	47,8	50	35	35	150	48

Per macchina / For machine: Biesse, Cosmec, Homag, Maka, Bulleri, Alberti, Reichenbacher, Masterwood, Busellato



ART.	ISO	D2 mm	H2 mm	D3 mm	H1 mm	D mm	H mm	D1 mm
2224020L70	40	44,45	68,4	63,55	35	20	70	35
2224030L70	40	44,45	68,4	63,55	35	30	70	45
2224030L80	40	44,45	68,4	63,55	35	30	80	45
2224030L100	40	44,45	68,4	63,55	35	30	100	45
2224030L150	40	44,45	68,4	63,55	35	30	150	45
2224035L70	40	44,45	68,4	63,55	35	35	70	50
2224035L80	40	44,45	68,4	63,55	35	35	80	50
2224035L100	40	44,45	68,4	63,55	35	35	100	50
2224035L150	40	44,45	68,4	63,55	35	35	150	50
2224040L70	40	44,45	68,4	63,55	35	40	70	55
2224040L80	40	44,45	68,4	63,55	35	40	80	55
2224040L100	40	44,45	68,4	63,55	35	40	100	55
2224040L150	40	44,45	68,4	63,55	35	40	150	55

Per macchina / For machine: SCM, Ima, Maka, Weeke, Stegheer, Reichenbacher

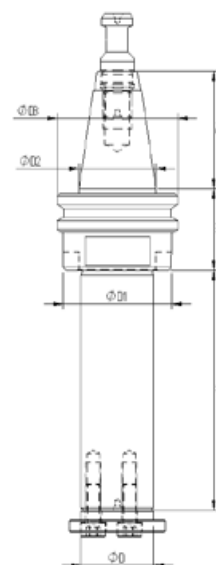

ART.	ISO	D2 mm	H2 mm	D3 mm	H1 mm	D mm	H mm	D1 mm
2233020L70	30	31,75	47,8	46	35	20	70	35
2233030L70	30	31,75	47,8	46	35	30	70	45
2233030L80	30	31,75	47,8	46	35	30	80	45
2233030L100	30	31,75	47,8	46	35	30	100	45
2233030L150	30	31,75	47,8	46	35	30	150	45
2233035L70	30	31,75	47,8	46	35	35	70	50
2233035L80	30	31,75	47,8	46	35	35	80	50
2233035L100	30	31,75	47,8	46	35	35	100	50
2233035L150	30	31,75	47,8	46	35	35	150	50

Per macchina / For machine: CMS

BILANCIATI FINO A G.2,5 - 24.000 RPM a richiesta
BALANCED TO 24,000 RPM at G.2,5 on request

MANDRINI PORTAFRESE MILLING CHUCKS

MANDRINI CON ALBERO PORTAFRESE ATTACCO DIN 69871 CHUCKS WITH END MILL ARBOR DIN 69871

ART.	ISO	D2 mm	H2 mm	D3 mm	H1 mm	D mm	H mm	D1 mm
2243020L70	30	31,75	47,8	58	35	20	70	35
2243030L70	30	31,75	47,8	58	35	30	70	45
2243030L80	30	31,75	47,8	58	35	30	80	45
2243030L100	30	31,75	47,8	58	35	30	100	45
2243030L150	30	31,75	47,8	58	35	30	150	45
2243035L70	30	31,75	47,8	58	35	35	70	50
2243035L80	30	31,75	47,8	58	35	35	80	50
2243035L100	30	31,75	47,8	58	35	35	100	50
2243035L150	30	31,75	47,8	58	35	35	150	50
2244020L70	40	44,45	68,4	58	35	20	70	35
2244030L70	40	44,45	68,4	58	35	30	70	45
2244030L80	40	44,45	68,4	58	35	30	80	45
2244030L100	40	44,45	68,4	58	35	30	100	45
2244030L150	40	44,45	68,4	58	35	30	150	45
2244035L70	40	44,45	68,4	58	35	35	70	50
2244035L80	40	44,45	68,4	58	35	35	80	50
2244035L100	40	44,45	68,4	58	35	35	100	50
2244035L150	40	44,45	68,4	58	35	35	150	50
2244040L70	40	44,45	68,4	58	35	40	70	55
2244040L80	40	44,45	68,4	58	35	40	80	55
2244040L100	40	44,45	68,4	58	35	40	100	55
2244040L150	40	44,45	68,4	58	35	40	150	55

Per macchina / For machine: Esseteam, Uniteam, Tekteam
BILANCIATI FINO A G.2,5 - 24.000 RPM a richiesta
BALANCED TO 24,000 RPM at G.2,5 on request

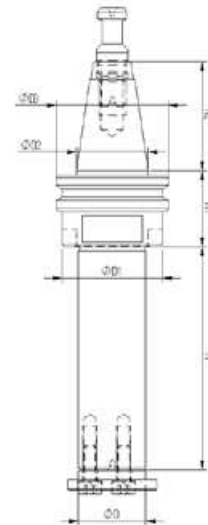

16

MANDRINI CON ALBERO PORTAFRESE FLANGIA DENTATA CHUCKS WITH END MILL ARBOR TOOTHED FLANGE

ART.	ISO	D mm	H mm	D1 mm	H1 mm
2223020L70SCM	30	20	70	35	41
2223030L70SCM	30	30	70	45	41
2223030L80SCM	30	30	80	45	41
2223030L100SCM	30	30	100	45	41
2223030L150SCM	30	30	150	45	41
2223035L70SCM	30	35	70	50	41
2223035L80SCM	30	35	80	50	41
2223035L100SCM	30	35	100	50	41
2223035L150SCM	30	35	150	50	41
2223040L70SCM	30	40	70	53	41
2223040L80SCM	30	40	80	53	41
2223040L100SCM	30	40	100	53	41
2223040L150SCM	30	40	150	53	41

Per macchina / For machine: SCM, Morbidelli
BILANCIATI FINO A G.2,5 - 24.000 RPM a richiesta
BALANCED TO 24,000 RPM at G.2,5 on request

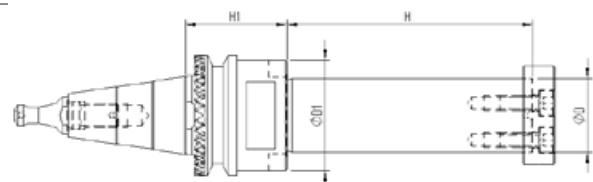

**RICAMBI
SPARE PARTS**

**TIRANTI PER MANDRINI
PULL STUDS FOR CHUCKS**

**ART.
ISO30BS**

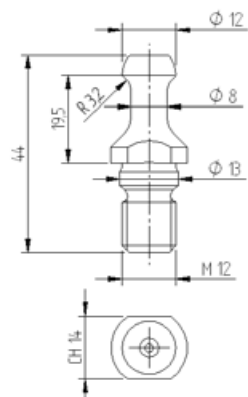

Per macchina / For machine: Elettromandri HSD, Biesse, Masterwood da fine 1999 / from 1999, Cosmec, etc

**ART.
ISO30SCM**

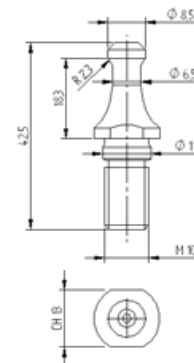

Per macchina / For machine: SCM, Morbidelli

**ART.
ISO30CMS**

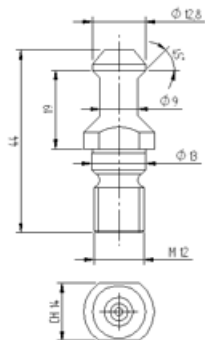

Per macchina / For machine: CMS

**ART.
ISO30GC**

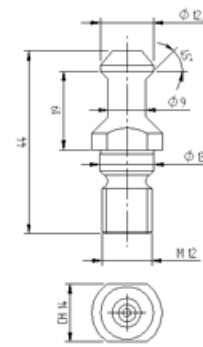

Per macchina / For machine: Elettromandri G. Colombo, Alberti, Masterwood fino a 1999 / from 1999

**ART.
DIN3015SF**

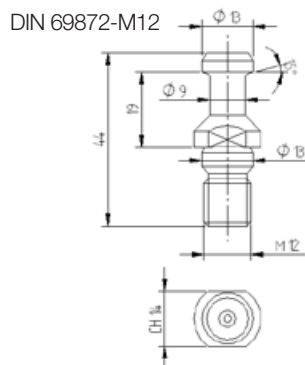

Per macchina/For machine: Elettromandri Elte, Ima, Maka, Weeke, Bulleri, Reichenbacher, Busellato, Esseteam, etc

**ART.
TC3015SF**

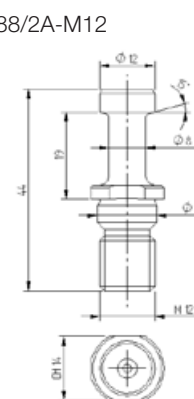

**ART.
DIN4015SF**

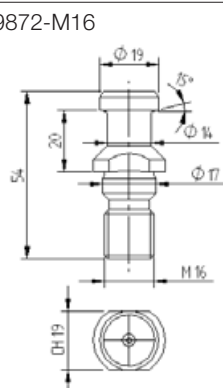

Per macchina / For machine: Ima, Maka, Reichenbacher, Uniteam, Tekteam, Esseteam, etc

**ART.
TC4015SF**

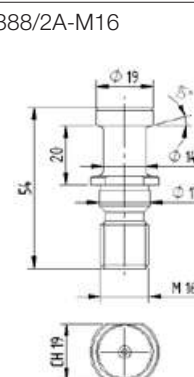

RICAMBI SPARE PARTS

GHIERE PER PINZE ER DIN 6499 NUTS FOR COLLETS ER DIN 6499

ART.	H mm	ER	D mm	M	D1 mm	Rot. Rev.
EPR32120GC	22,5	32	3-20	M40x1,5	50	dx / r
EPR32120GCSX	22,5	32	3-20	M40x1,5	50	sx / l
EPR40120GC	25,5	40	4-30	M50x1,5	63	dx / r
EPR40120GCSX	25,5	40	4-30	M50x1,5	63	sx / l

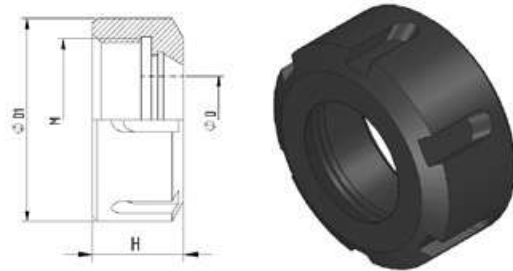

GHIERE PER PINZE ER DIN 6499 CON SFERE NUTS FOR COLLETS ER DIN 6499 WITH BEARING BALLS

ART.	H mm	ER	D mm	M	D1 mm	Rot. Rev.
EPR32130G	26	32	3-20	M40x1,5	50	dx / r
EPR40130G	29	40	4-30	M50x1,5	63	dx / r

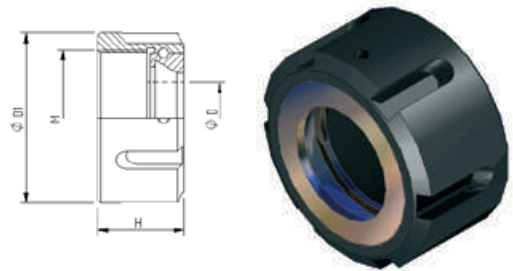

PINZE ER DIN 6499/B COLLETS ER DIN 6499/B

ER32

ART.	D mm
EPR32030	3
EPR32040	4
EPR32050	5
EPR32060	6
EPR32070	7
EPR32080	8
EPR32090	9
EPR32100	10
EPR32110	11

ART.	D mm
EPR32120	12
EPR32130	13
EPR32140	14
EPR32150	15
EPR32160	16
EPR32170	17
EPR32180	18
EPR32190	19
EPR32200	20

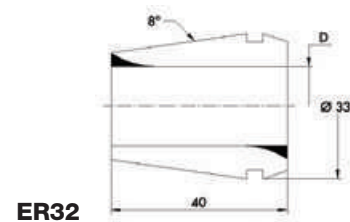

ER32

ER40

ART.	D mm
EPR40030	3
EPR40040	4
EPR40050	5
EPR40060	6
EPR40070	7
EPR40080	8
EPR40090	9
EPR40100	10
EPR40110	11
EPR40120	12
EPR40130	13
EPR40140	14
EPR40150	15
EPR40160	16

ART.	D mm
EPR40170	17
EPR40180	18
EPR40190	19
EPR40200	20
EPR40210	21
EPR40220	22
EPR40230	23
EPR40240	24
EPR40250	25
EPR40260	26
EPR40270	27
EPR40280	28
EPR40290	29
EPR40300	30

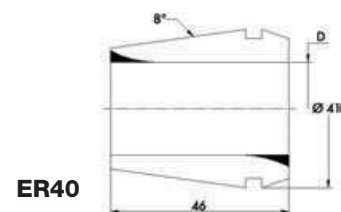

ER40

**RICAMBI
SPARE PARTS**

**GHIERA PER PINZE EOP DIN 6388 CON SFERE
NUT FOR COLLETS EOP DIN 6388 WITH BEARING BALLS**

ART.	H mm	EOP	D mm	M	D1 mm	Rot. Rev.
EOP25130G	30	25	2-25	M48x2	60	dx / r

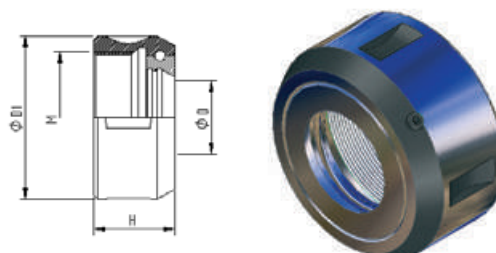

PINZE EOP DIN 6388/B / COLLETS EOP DIN 6388/B

ART.	D mm	ART.	D mm
EOP25025	2,5	EOP25140	14
EOP25030	3	EOP25145	14,5
EOP25035	3,5	EOP25150	15
EOP25040	4	EOP25155	15,5
EOP25045	4,5	EOP25160	16
EOP25050	5	EOP25165	16,5
EOP25055	5,5	EOP25170	17
EOP25060	6	EOP25175	17,5
EOP25065	6,5	EOP25180	18
EOP25070	7	EOP25185	18,5
EOP25075	7,5	EOP25190	19
EOP25080	8	EOP25195	19,5
EOP25085	8,5	EOP25200	20
EOP25090	9	EOP25205	20,5
EOP25095	9,5	EOP25210	21
EOP25100	10	EOP25215	21,5
EOP25105	10,5	EOP25220	22
EOP25110	11	EOP25225	22,5
EOP25115	11,5	EOP25230	23
EOP25120	12	EOP25235	23,5
EOP25125	12,5	EOP25240	24
EOP25130	13	EOP25245	24,5
EOP25135	13,5	EOP25250	25

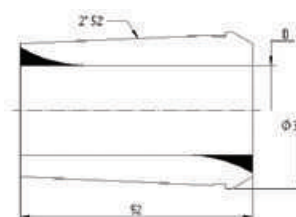

GHIERE ETS32 - ETS40 / NUTS ETS32 - ETS40

ART.	H mm	ETS	D mm	M	D1 mm	Rot. Rev.
ETS32120G	22,5	32	3-20	M40x1,5	50	dx / r
ETS32120GSX	22,5	32	3-20	M40x1,5	50	sx / l
ETS40120G	26	40	4-30	M50x1,5	63	dx / r
ETS40120GSX	26	40	4-30	M50x1,5	63	sx / l

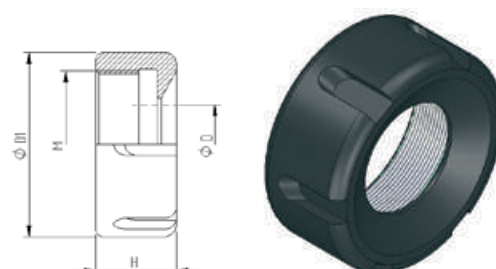

RICAMBI SPARE PARTS

PINZE ETS32 - ETS40 / COLLETS ETS32- ETS40

ETS32

ART.	D mm
ETS32030	3
ETS32040	4
ETS32050	5
ETS32060	6
ETS32070	7
ETS32080	8
ETS32090	9
ETS32100	10
ETS32110	11

ART.	D mm
ETS32120	12
ETS32130	13
ETS32140	14
ETS32150	15
ETS32160	16
ETS32170	17
ETS32180	18
ETS32190	19
ETS32200	20

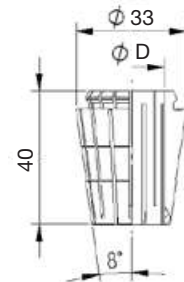

ETS32

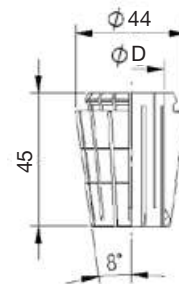
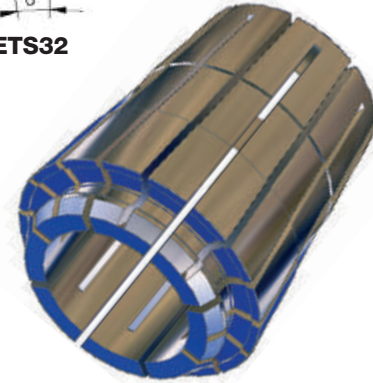

ETS40

ETS40

ART.	D mm
ETS40040	4
ETS40050	5
ETS40060	6
ETS40070	7
ETS40080	8
ETS40090	9
ETS40100	10
ETS40110	11
ETS40120	12
ETS40130	13
ETS40140	14
ETS40150	15

ART.	D mm
ETS40160	16
ETS40170	17
ETS40180	18
ETS40190	19
ETS40200	20
ETS40210	21
ETS40220	22
ETS40230	23
ETS40240	24
ETS40250	25
ETS40260	26

GHIERE DI CONTRASTO PER MANDRINI PORTAPINZE SPACERS FOR COLLET CHUCKS

ART.	H mm	D mm	M	Rot. Rev.
EPR32150GC	8	50	M40X1,5	dx / r
EPR32150GCSX	8	50	M40X1,5	sx / l
EPR40150GC	8	63	M50X1,5	dx / r
EPR40150GCSX	8	63	M50X1,5	sx / l

Per macchina / For machine: Uniteam, Tekteam, Esseteam

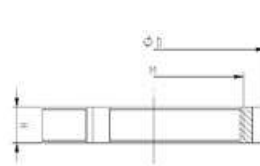

VITI DI BLOCCAGGIO PER FLANGIA ARBOR SCREWS

ART.	H1 mm	H mm	M	D1 mm
VIBLOM5	5	16	M5	8,5
VIBLOM6	6	16	M6	10

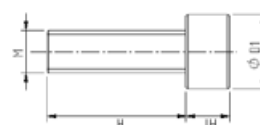

**RICAMBI
SPARE PARTS**

**FLANGE DI BLOCCAGGIO RIDOTTA
REDUCED LOCKING FLANGES**

ART.	H1 mm	H mm	D mm	D1 mm	D2 mm
FLABRI20	13	4	20	30	12
FLABRI25	13	4	25	35	16
FLABRI30	13	4	30	40	20
FLABRI35	13	4	35	45	24
FLABRI40	13	4	40	50	28

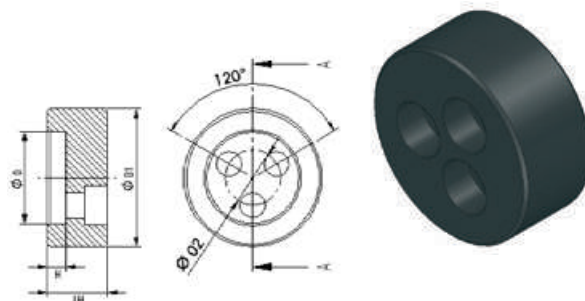

**FLANGE DI BLOCCAGGIO ESPANSA
EXPANDED LOCKING FLANGES**

ART.	H1 mm	H mm	D mm	D1 mm	D2 mm
FLABES20	10	4	20	30	12
FLABES25	10	4	25	35	16
FLABES30	9	4	30	40	20
FLABES35	9	4	35	45	24
FLABES40	9	4	40	50	28

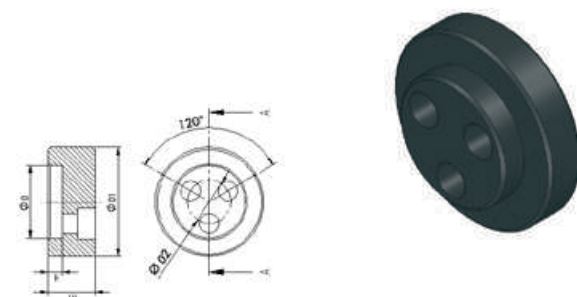

CHIAVI PER GHIERA / NUT WRENCHES

ART.	Ghiera Nut
EPR32180CH	EPR32120G
EPR40180CH	EPR40120G



ART.	Ghiera Nut
EOP25180CHS	EOP25130G



**SMONTACONI A RUOTA LIBERA
TOOL SETTING STANDS**

ART.	HSK
HSK40SMRL	40
HSK50SMRL	50
HSK63SMRL	63

